

DATA SHEET

HPW HIGH PRESSURE WATER PUMPS

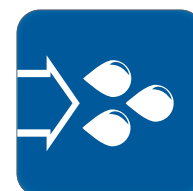

HPW160
HPW250
HPW420
HPW220

HPW90
HPW520
HPW180
HPW460

HPW320
HPW130
HPW800
HPW1600

HPW1000
HPW360
HPW300
HPW1200





HPW HIGH PRESSURE WATER PUMPS TABLE OF CONTENTS

v.1.5 05/2024 WNu

1. DIMENSIONS	4
2. CONNECTIONS	6
3. TECHNICAL SPECIFICATIONS	7

1. DIMENSIONS

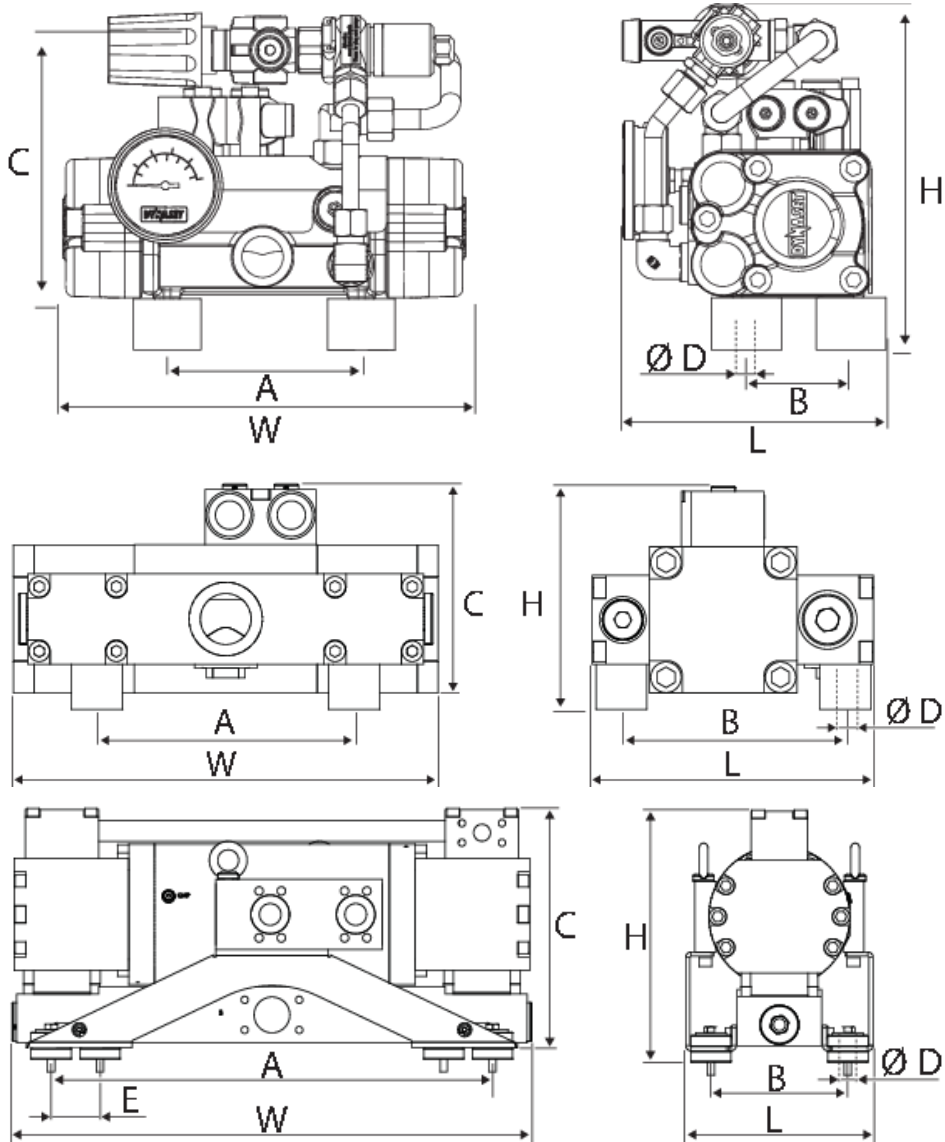



HPW HIGH PRESSURE WATER PUMPS DIMENSIONS

Model	Dimensions, mm (in)									Weight
	L	W	H	A	B	C	D ¹	D ²	E	kg (lbs)
HPW160/18-18	145 (5.7)	210 (8.3)	125 (4.9)	74 (2.9)	64 (2.5)	100 (3.9)	6 (0.2)	()	()	6.2 (14)
HPW250/30-40	170 (6.7)	240 (9.4)	180 (7.1)	115 (4.5)	60 (2.4)	146 (5.7)	8 (0.3)	()	()	11 (24)
HPW420/20-50	175 (6.9)	245 (9.6)	215 (8.5)	115 (4.5)	60 (2.4)	125 (4.9)	8 (0.3)	()	()	15 (33)
HPW220/50-70	270 (10.6)	280 (11.0)	235 (9.3)	126 (5.0)	106 (4.2)	153 (6.0)	8 (0.3)	()	()	15 (33)
HPW90/150-85	235 (9.3)	345 (13.6)	275 (10.8)	252 (9.9)	95 (3.7)	250 (9.8)	10 (0.4)	()	()	28 (62)
HPW520/30-85	135 (5.3)	290 (11.4)	170 (6.7)	115 (4.5)	80 (3.1)	145 (5.7)	8 (0.3)	()	()	20 (44)
HPW180/90-115	235 (9.3)	330 (13.0)	175 (6.9)	200 (7.9)	175 (6.9)	160 (6.3)	10 (0.4)	()	()	27 (60)
HPW460/50-115	200 (7.9)	320 (12.6)	200 (7.9)	155 (6.1)	155 (6.1)	167 (6.6)	8 (0.3)	()	()	32 (71)
HPW320/75-125	230 (9.1)	344 (13.5)	200 (7.9)	155 (6.1)	155 (6.1)	220 (8.7)	8 (0.3)	()	()	33 (73)
HPW130/180-140	260 (10.2)	400 (15.7)	180 (7.1)	250 (9.8)	95 (3.7)	270 (10.6)	10 (0.4)	()	()	44 (97)
HPW800/30-140	190 (7.5)	340 (13.4)	195 (7.7)	155 (6.1)	155 (6.1)	220 (8.7)	8 (0.3)	()	()	39 (86)
HPW1600/15-140	200 (7.9)	405 (15.9)	200 (7.9)	155 (6.1)	155 (6.1)	120 (4.7)	10 (0.4)	()	()	36 (79)
HPW1000/30-140	210 (8.3)	380 (15.0)	200 (7.9)	110 (4.3)	64 (2.5)	164 (6.5)	8 (0.3)	()	()	32 (71)
HPW360/220-360	305 (12.0)	740 (29.1)	365 (14.4)	630 (24.8)	194 (7.6)	340 (13.4)	16 (0.6)	16 (0.6)	70 (2.8)	150 (331)
HPW300/300-350	270 (10.6)	745 (29.3)	360 (14.2)	630 (24.8)	194 (7.6)	340 (13.4)	16 (0.6)	16 (0.6)	70 (2.8)	170 (375)
HPW1200/100-440	270 (10.6)	915 (36.0)	350 (13.8)	630 (24.8)	194 (7.6)	335 (13.2)	16 (0.6)	16 (0.6)	70 (2.8)	177 (391)
D¹ threaded hole										
D² unthreaded hole										

2. CONNECTIONS

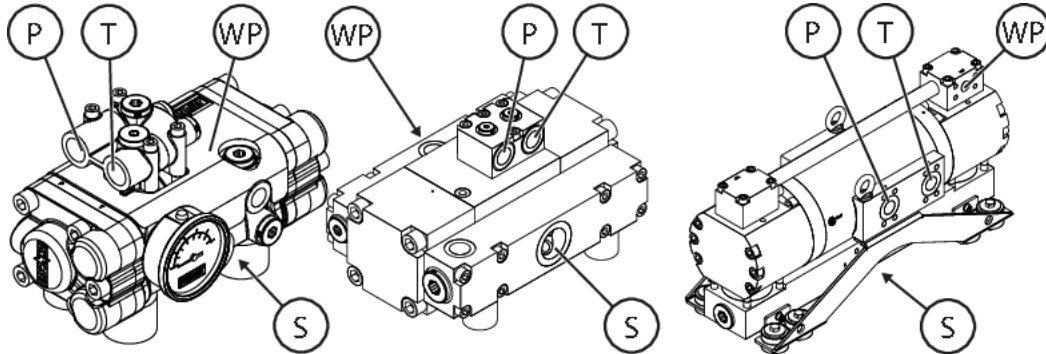

Model	Connections					Hose size min, mm (in)
	Pressure Line, P	Return Line, T	Service Line, CMP	Water Output, WP	Water Input, S	
HPW160/18-18	BSPP 3/8	BSPP 3/8	BSPP 1/8	BSPP 3/8	BSPP 3/4	19 (3/4)
HPW250/30-40	BSPP 1/2	BSPP 1/2	-	BSPP 3/8	BSPP 3/4	25 (1)
HPW420/20-50	BSPP 1/2	BSPP 1/2	BSPP 1/8	BSPP 3/8	BSPP 3/4	19 (3/4)
HPW220/50-70	BSPP 3/4	BSPP 3/4	BSPP 1/8	BSPP 1/2	BSPP 1	25 (1)
HPW90/150-85	BSPP 3/4	BSPP 3/4	BSPP 1/8	BSPP 1	BSPP 2	50 (2)
HPW520/30-85	BSPP 3/4	BSPP 3/4	BSPP 1/8	BSPP 3/8	BSPP 3/4	25 (1)
HPW180/90-115	BSPP 3/4	BSPP 3/4	BSPP 1/8	BSPP 3/4	BSPP 1 1/4	38 (1 1/2)
HPW460/50-115	BSPP 3/4	BSPP 3/4	BSPP 1/8	BSPP 1/2	BSPP 1	25 (1)
HPW320/75-125	BSPP 3/4	BSPP 3/4	BSPP 1/8	BSPP 1/2	BSPP 1 1/4	32 (1 1/4)
HPW130/180-140	BSPP 3/4	BSPP 3/4	BSPP 1/8	BSPP 1	BSPP 2	50 (2)
HPW800/30-140	BSPP 3/4	BSPP 3/4	BSPP 1/8	BSPP 3/8	BSPP 3/4	25 (1) *
HPW1600/15-140	BSPP 3/4	BSPP 3/4	BSPP 1/8	HP 1/4	BSPP 1/2	13 (1/2) *
HPW1000/30-140	BSPP 3/4	BSPP 3/4	BSPP 1/8	MP 9/16	BSPP 3/4	19 (3/4) *
HPW360/220-360	SAE 6000 1 1/4	SAE 6000 1 1/4	BSPP 1/8	SAE 6000 1	SAE 3000 2	63 (2 1/2)
HPW300/300-350	SAE 6000 1 1/4	SAE 6000 1 1/4	BSPP 1/8	SAE 6000 1	SAE 3000 2	63 (2 1/2)
HPW1200/100-440	SAE 6000 1 1/4	SAE 6000 1 1/4	BSPP 1/8	MP 3/4	SAE 3000 2	38 (1 1/2) *

*Pressurized Water Feed

3. TECHNICAL SPECIFICATIONS

		HPW160/ 18-18	HPW250/ 30-40	HPW420/ 20-50	HPW220/ 50-70	HPW90/ 150-85	HPW520/ 30-85
DISCHARGE CHARACTERISTICS							
Pumping fluid flow max.	l/min (gpm)	18 (4.76)	30 (7.93)	20 (5.28)	50 (13.21)	150 (39.63)	30 (7.93)
Pressure max.	bar (psi)	160 (2,321)	250 (3,626)	420 (6,092)	220 (3,191)	90 (1,305)	520 (7,542)
Power	kW	4.8	12.5	14	18.5	22.5	26
Water/hydraulic pressure ratio		0.88	1.18	2.12	1.26	0.52	2.62
HYDRAULIC POWER REQUIREMENTS							
Flow max.	l/min (gpm)	18 (4.76)	40 (10.57)	50 (13.21)	70 (18.49)	85 (22.46)	85 (22.46)
Operating pressure	Δp.bar (psi)	210 (3,046)	250 (3,626)	210 (3,046)	210 (3,046)	210 (3,046)	230 (3,336)
Pressure max.	bar (psi)	210 (3,046)	260 (3,771)	220 (3,191)	210 (3,046)	210 (3,046)	250 (3,626)
HYDRAULIC FLUID REQUIREMENTS							
Viscosity	cSt	10-200 / optimum 25-35	10-200 / optimum 25-35	10-200 / optimum 25-35	10-200 / optimum 25-35	10-200 / optimum 25-35	10-200 / optimum 25-35
Temperature max.	°C(°F)	70 (158)	70 (158)	70 (158)	70 (158)	70 (158)	70 (158)
Filter ratio	µm	<25	<25	<25	<25	<25	<25
Cooling capacity requirement	kW	1	2.5	2	3	4	4
PUMPING FLUID REQUIREMENTS							
Suction head Above sea level max.	m (ft)	3 (10)	3 (10)	3 (10)	3 (10)	3 (10)	3 (10)
Feed pressure	bar (psi)	-0.3 (-4) - 16 (232)	-0.3 (-4) - 16 (232)	-0.3 (-4) - 16 (232)	-0.3 (-4) - 16 (232)	-0.3 (-4) - 16 (232)	-0.3 (-4) - 16 (232)
Water filter	mesh	80	80	80	80	80	80

		HPW180/ 90-115	HPW460/ 50-115	HPW320/ 75-125	HPW130/ 180-140	HPW800/ 30-140	HPW1600/ 15-140
DISCHARGE CHARACTERISTICS							
Pumping fluid flow max.	l/min (gpm)	90 (23.78)	50 (13.21)	75 (19.82)	180 (47.56)	30 (7.93)	15 (3.96)
Pressure max.	bar (psi)	180 (2,611)	460 (6,672)	320 (4,641)	130 (1,885)	800 (11,603)	1,600 (23,206)
Power	kW	27	38	40	39	40	40
Water/hydraulic pressure ratio		1.12	2.03	1.5	0.68	4	7.87
HYDRAULIC POWER REQUIREMENTS							
Flow max.	l/min (gpm)	115 (30.38)	115 (30.38)	125 (33.03)	140 (36.99)	140 (36.99)	140 (36.99)
Operating pressure	Δp.bar (psi)	210 (3,046)	240 (3,481)	240 (3,481)	240 (3,481)	210 (3,046)	230 (3,336)
Pressure max.	bar (psi)	210 (3,046)	250 (3,626)	250 (3,626)	250 (3,626)	210 (3,046)	230 (3,336)
HYDRAULIC FLUID REQUIREMENTS							
Viscosity	cSt	10-200 / optimum 25-35	10-200 / optimum 25-35	10-200 / optimum 25-35	10-200 / optimum 25-35	10-200 / optimum 25-35	10-200 / optimum 25-35
Temperature max.	°C(°F)	70 (158)	70 (158)	70 (158)	70 (158)	70 (158)	70 (158)
Filter ratio	µm	<25	<25	<25	<25	<25	<25
Cooling capacity requirement	kW	6	5	6	6	6	6
PUMPING FLUID REQUIREMENTS							
Suction head Above sea level max.	m (ft)	3 (10)	3 (10)	3 (10)	3 (10)	2 (7)	()
Feed pressure	bar (psi)	-0.3 (-4) - 16 (232)	-0.3 (-4) - 16 (232)	-0.3 (-4) - 16 (232)	-0.3 (-4) - 16 (232)	-0.2 (-3) - 16 (232)	3 (44) - 16 (232)
Water filter	mesh	80	80	80	80	80	625

		HPW1000/ 30-140	HPW360/ 220-360	HPW300/ 300-350	HPW1200/ 100-440
DISCHARGE CHARACTERISTICS					
Pumping fluid flow max.	l/min (gpm)	30 (7.93)	220 (58.12)	300 (79.26)	100 (26.42)
Pressure max.	bar (psi)	1,000 (14,504)	360 (5,221)	300 (4,351)	1,200 (17,405)
Power	kW	50	132	150	200
Water/hydraulic pressure ratio		4	1.5	1.06	4
HYDRAULIC POWER REQUIREMENTS					
Flow max.	l/min (gpm)	140 (36.99)	360 (95.11)	350 (92.47)	440 (116.25)
Operating pressure	Δp.bar (psi)	260 (3,771)	250 (3,626)	350 (5,076)	300 (4,351)
Pressure max.	bar (psi)	280 (4,061)	250 (3,626)	350 (5,076)	350 (5,076)
HYDRAULIC FLUID REQUIREMENTS					
Viscosity	cSt	10-200 / optimum 25-35	10-200 / optimum 25-35	10-200 / optimum 25-35	10-200 / optimum 25-35
Temperature max.	°C(°F)	70 (158)	70 (158)	70 (158)	70 (158)
Filter ratio	µm	<25	<25	<25	<25
Cooling capacity requirement	kW	8	25	30	35
PUMPING FLUID REQUIREMENTS					
Suction head Above sea level max	m (ft)	()	3 (10)	()	()
Feed pressure	bar (psi)	3 (44) - 20 (290)	-0.3 (-4) - 16 (232)	-0.3 (-4) - 16 (232)	3 (44) - 16 (232)
Water filter	mesh	625	80	80	625



HPW HIGH PRESSURE WATER PUMPS TECHNICAL SPECIFICATIONS



POWERED BY HYDRAULICS

Menotie 3
FI-33470 Ylöjärvi, Finland
tel: +358 3 3488 200
info@DYNASET.com



ELECTRICITY

HG Hydraulic Generator
HGV POWER BOX Variable Hydraulic
Generator System
HGV Variable Hydraulic Generator System
HWG Hydraulic Welding Generator
HGG Hydraulic Ground Power Generator



HIGH PRESSURE WATER

HPW Hydraulic High Pressure Water Pump
HPW Hydraulic Power Washer
KPL High Pressure Street Washing Unit
KPL-WEED Weed Killing Unit
SCU Surface Cleaning Unit
HPW-DUST High Pressure Dust Suppression
System
PPL High Pressure Pipe Cleaning Unit
HPW-FIRE High Pressure Firefighting System
FP Fire Fighting Piercing Kit
HDF Hydraulic Drilling Fluid Pump
JPL High Pressure Bin Washing System
HSP Hydraulic Submersible Pump



COMPRESSED AIR

HK Hydraulic Piston Compressor
HKL Hydraulic Rotary Vane Compressor
HKR Hydraulic Screw Compressor



MAGNET POWER

HMG PRO Hydraulic Magnet Generator
MAG Lift Magnet
HMAG PRO Hydraulic Magnet



VIBRATION

HVB Hydraulic Vibration Pump
HVD Hydraulic Directional Vibra
HRC Hydraulic Reversal Cylinder



POWER BOOSTING

HPI Hydraulic Pressure Intensifier
HPI-C Hydraulic Pressure Intensifier for
Cylinder



VACUUM

HCF Hydraulic Centrifugal Fan
HRVB Hydraulic Recycling Vacuum Bucket



KNOW-HOW

Hydraulic Power Take-off (PTO)
Hydraulic Power Unit Technology
HEU Hydraulic Expansion Unit
HRU Hydraulic Rescue Units
De-Icing Technology
Installation Valves
HHK Hydraulic Grinder
HV/HVY Hydraulic Winch / Winch Unit

www.DYNASET.com



[/dynaset](https://www.facebook.com/dynaset)



[/dynasetoy](https://www.youtube.com/dynasetoy)



[/Dynaset_ofcl](https://twitter.com/Dynaset_ofcl)



[/dynaset_official](https://www.instagram.com/dynaset_official)